

MALE END VIEW	FEMALE END VIEW	WIRING DIAGRAM	SPECIFICATIONS																							
			<table border="1"> <tr><td>CONTACT CARRIER MATERIAL</td><td>NYLON OR TPU</td></tr> <tr><td>MOLDED HEAD MATERIAL/COLOR</td><td>TPU/YELLOW</td></tr> <tr><td>CONTACT MATERIAL/PLATING</td><td>BRASS/GOLD</td></tr> <tr><td>COUPLING NUT MATERIAL/PLATING</td><td>BRASS/NICKEL</td></tr> <tr><td>RATED CURRENT [A]</td><td>4.0 A</td></tr> <tr><td>RATED VOLTAGE [V]</td><td>250 V</td></tr> <tr><td>OUTER JACKET MATERIAL/COLOR</td><td>PVC/GRAY</td></tr> <tr><td>CONDUCTOR INSULATION MATERIAL</td><td>PVC</td></tr> <tr><td>NUMBER OF CONDUCTOR [AWG]</td><td>3x22 AWG</td></tr> <tr><td>TEMPERATURE RATING</td><td>-40°C to +105°C (-40°F to +221°F)</td></tr> <tr><td>PROTECTION CLASS</td><td>MEETS NEMA 1,3,4,6P AND IEC IP68</td></tr> </table>	CONTACT CARRIER MATERIAL	NYLON OR TPU	MOLDED HEAD MATERIAL/COLOR	TPU/YELLOW	CONTACT MATERIAL/PLATING	BRASS/GOLD	COUPLING NUT MATERIAL/PLATING	BRASS/NICKEL	RATED CURRENT [A]	4.0 A	RATED VOLTAGE [V]	250 V	OUTER JACKET MATERIAL/COLOR	PVC/GRAY	CONDUCTOR INSULATION MATERIAL	PVC	NUMBER OF CONDUCTOR [AWG]	3x22 AWG	TEMPERATURE RATING	-40°C to +105°C (-40°F to +221°F)	PROTECTION CLASS	MEETS NEMA 1,3,4,6P AND IEC IP68	
CONTACT CARRIER MATERIAL	NYLON OR TPU																									
MOLDED HEAD MATERIAL/COLOR	TPU/YELLOW																									
CONTACT MATERIAL/PLATING	BRASS/GOLD																									
COUPLING NUT MATERIAL/PLATING	BRASS/NICKEL																									
RATED CURRENT [A]	4.0 A																									
RATED VOLTAGE [V]	250 V																									
OUTER JACKET MATERIAL/COLOR	PVC/GRAY																									
CONDUCTOR INSULATION MATERIAL	PVC																									
NUMBER OF CONDUCTOR [AWG]	3x22 AWG																									
TEMPERATURE RATING	-40°C to +105°C (-40°F to +221°F)																									
PROTECTION CLASS	MEETS NEMA 1,3,4,6P AND IEC IP68																									

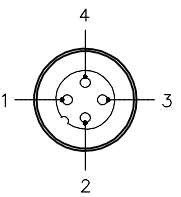
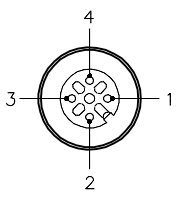
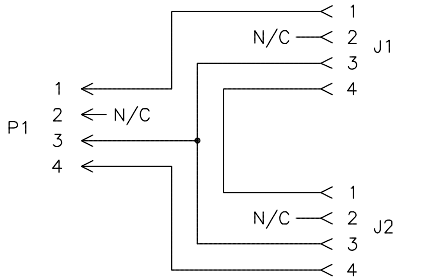
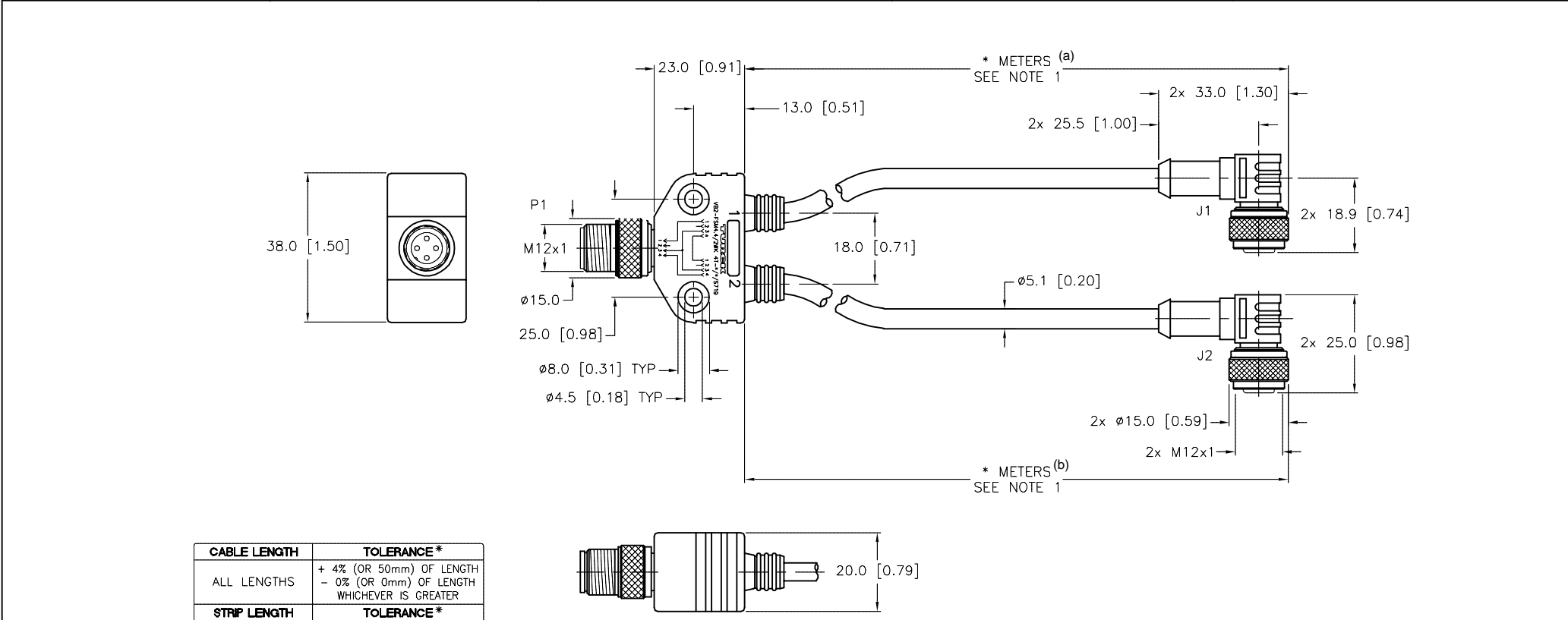

CABLE LENGTH	TOLERANCE*
ALL LENGTHS	+ 4% (OR 50mm) OF LENGTH - 0% (OR 0mm) OF LENGTH WHICHEVER IS GREATER
STRIP LENGTH	TOLERANCE*
0-7mm	±0.5mm
8-29mm	±1.0mm
30-49mm	±2.0mm
50-69mm	±3.0mm
70-100mm	±4.0mm
OVER 100mm	±5.0mm

\* UNLESS OTHERWISE SPECIFIED

- NOTES:
- "\*" INDICATES CABLE LENGTH IN METERS. CONTACT TURCK TO ORDER SPECIFIC LENGTHS.
  - "/S719" DESIGNATES SERIES WIRING.

SOURCE DRAWING - FOR REFERENCE ONLY

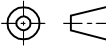
RELATED DOCUMENTS 1. 2. 3. 4.	3RD ANGLE PROJECTION 	THIS DRAWING IS CONFIDENTIAL AND THE PROPERTY OF TURCK INC. USE OF THIS DOCUMENT WITHOUT WRITTEN PERMISSION IS PROHIBITED.	3000 CAMPUS DRIVE MINNEAPOLIS, MN 55441 1-800-544-7769 (763) 553-7300 (763) 553-0708 fax www.turck.us
MATERIAL  SEE SPECIFICATIONS  FINISH  SEE SPECIFICATIONS	ALL DIMENSIONS DISPLAYED ON THIS DRAWING ARE FOR REFERENCE ONLY  CONTACT TURCK FOR MORE INFORMATION	DRFT RWC DATE 02/22/07 APVD SCALE 1=1.5 UNIT OF MEASUREMENT <b>MILLIMETER [ INCH ]</b>	DESCRIPTION <b>TURCK</b> VB2-FSM 4.4/2WK 4T-*/*/S719 (a) (b) IDENTIFICATION NO. REV 
DO NOT SCALE THIS DRAWING		FILE: 777016263 SHEET 1 OF 1	

I	UPDATE MALE COUPLING NUT	NF	04/24/18	56903
REV	DESCRIPTION	BY	DATE	ECO NO.